



**Performance Products**

**2025 Set-Up  
Equipment Catalog**

**MAX SPEED. NO COMPROMISES.**



## Making Race Cars Consistently Fast is Hard.

The first 98% of speed is relatively simple.

The last 2% (the difference between winning and average) can be incredibly complex and expensive!

Our goal at DRP Performance is to design and build tools that make the last 2%:

- Less Complex to Understand
  - Easier to Find
  - More Consistent & Less Expensive.

The right information (*Data*) gives you more clarity and understanding of what your race car is doing. Clarity lowers stress and allows for better decisions to be made.

Data comes from good tools and processes. (*Equipment*)

Good training enables you to understand and make the best decisions with your data. (*Training*)

Bad decisions (Guessing, Gambling, Hoping) is what takes the most time and costs the most money!

*How we can help you find more speed and win more races:*



*Spring loads & platform are an essential component for set-up consistency and handling adjustment at the track.*

*Accu-Force Spring Smashers are the premium spring load machines on the market. Max Speed. No Compromises.*



*Wheel positions (toe, camber, caster, rear skew, tread width, etc.) are foundational to set-up success. Miss these and your day at the track will be a struggle. Real Square Tools save time and increase your accuracy. Max Speed. No Compromises.*



*Balance is the ultimate chassis tuning tool. Master it and you look like a hero. DRP set-up systems take your balance measurements to the next level in the shop. DRP data acquisition systems measure what you can't see at the track. Max Speed. No Compromises.*



*What good is all this information if you don't understand it or know how to properly use it? DRP University brings you on-line training, live seminars & workshops and personal set-up services.*

**888-399-6074**

**[DRPperformance.net](http://DRPperformance.net)**

**[DRPuniversity.tv](http://DRPuniversity.tv)**

# Accu-Force<sup>®</sup> Spring Smasher

## GEN-3 Automatic

The fastest and most accurate way to change coil-over springs.

- Gen 3 Design for Maximum Accuracy
- Integrated Spring Unloader Eliminates Removing Shock to Change Spring.
- Extra Clearance when Unloading Springs.
- Canister Cup™ Quickly & Securely Holds Gas Canister.
- Wheel Kit for Portability.
- Pin Holders for Speed

Automated for Fast & Repeatable Tests

On Screen Graphing with Overlay

USB Download

Push & Pull Modes

Professional Grade Control  
Fast, Automated Tests



Main Screen Displays Center to Center & Spring Load.  
Select Push or Pull Mode.

49 Test Pre-Sets. Store 199 Saved Tests.

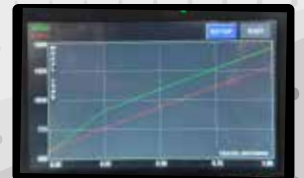

Overlay Graphs to Compare Tests.  
Graph Compression & Rebound.



Manual Mode for Simple Manual Tests.  
Quick Tap to Zero Load and Travel.

AF3500 Accu-Force<sup>®</sup> Automated Spring Smasher - Base Model \$7195.00

AF3550 Accu-Force<sup>®</sup> Automated Spring Smasher - Loaded \$7595.00

Loaded Model Includes Spring Unloader, Canister Cup & Wheel Kit.



FINANCING  
AVAILABLE

888-399-6074

DRPperformance.net

DRPuniversity.tv

# Accu-Force® Spring Smasher

## Standard III Spring Smasher

- Simple & Fast Touch Screen Displays Shock Centerline, Load & Travel
  - Tap Screen to Zero Weight or Travel
  - Electric Actuator with Toggle Switch Control
  - Extension Over-limit
- Optional Integrated Spring Unloader Eliminates Removing Shock to Change Spring.
  - Optional Wheel Kit for Portability.
  - Pin Holders for Speed



Main Touch Screen Displays Center to Center & Spring Load.



Quick Tap to Zero Load and Travel.  
Select Push or Pull Mode.  
(Push Mode Prevents over Extending Shock)

AF3100 Accu-Force® Standard II Spring Smasher \$3995.00

*The Standard III's greatest feature is its simplicity.*

*One Screen, Push or Pull Mode.  
Manual Toggle Control*



FINANCING  
AVAILABLE

**Repeatable Set-Ups.  
Improved Performance.**



# Accu-Force® Spring Smasher

4

888-399-6074  
DRPperformance.net  
DRPuniversity.tv

# XL SXS Automatic Spring Smasher

- UTV
- SXS
- Off Road
- 18" Stroke
- Fully Automated
- Measure Spring Load through Travel
- Measure Low Speed Shock Valving & Adjustments
- Measures & Graphs Compression & Rebound
- Set Spring Load, Lock Out Nuts
- Check for Binds
- Store & Graph Data
- USB Data Download
- Match Shocks & Springs
- Remove & Replace Pre-Loaded Springs without adjusting Coil Over Nuts!



**Professional Grade Control  
Fast, Automated Tests**



Main Screen Displays Center to Center & Spring Load.  
Select Push or Pull Mode.  
49 Test Pre-Sets. Store 199 Saved Tests.

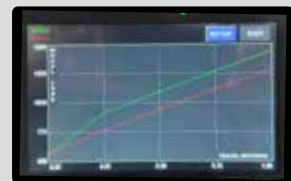

Overlay Graphs to Compare Tests.  
Graph Compression & Rebound.



Manual Mode for Simple Manual Tests.  
Quick Tap to Zero Load and Travel.

**AF3600**  
**Accu-Force® XL SXS Spring Smasher**  
**\$7295.00**

888-399-6014  
DRPperformance.net  
DRPuniversity.tv

# Spring Smasher Accessories



GEN-2 Swivel Unloader  
Captures Spring  
AF1910 \$275.00



One Piece Unloader  
with Indicator Clearance  
AF1920 \$275.00



Canister Cup  
for Canister Style Shocks  
AF1950 \$98.75



Spring Rate Adapters  
AF1985 C/O \$149.00  
AF1980 CONV \$229.00



Pull Bar & Trailing Arm  
Adapter Kits  
AF1958 5/8" \$135.00  
AF1834 3/4" \$135.00



3 Piece Spring Unloader  
Remove-able Plates  
to Adjust Spring Size  
AF1930 \$459.00



Wheel Kit  
AF1800 \$72.00



New Billet Pins  
AF1812 \$30.90

## Specialty Adapters

Quarter Midget Adapters

AF1860 \$135.

Drag Race Clevis'

AF1865 60.

Short Shock Extension

AF1870 \$60.

SXS/UTV Clevis'

AF1875 \$70.

888-399-6074  
DRPperformance.net  
DRPuniversity.tv

**Accu-Force**  
Spring Smasher

# Bar Dyno



- Torsion Bars
- Sway Bars
- Axles

- Measure Bar Rate
- Hysteresis
- Graphing
- Data Download

- Industrial Touch Screen
- 24" -37" Length

**Accu-Force®**  
Spring Smasher

AF5000 Accu-Force® BAR DYNO \$7150.00  
Specify Torsion Bar, Sway Bar or Axle



TRAVEL DISTANCE	LOAD	BAR RATE	SPRING CONSTANT
0.000	0	0	+0
0.125	184	147	+28
0.250	368	294	+56
0.375	552	441	+84
0.500	736	588	+112
0.625	920	735	+140
0.750	1104	882	+168
0.875	1288	1029	+196
1.000	1472	1176	+224
1.125	1656	1323	+252
1.250	1840	1470	+280
1.375	2024	1617	+308
1.500	2208	1764	+336
1.625	2392	1911	+364
1.750	2576	2058	+392

MAN AUTO DATA

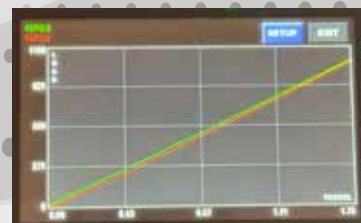

888-399-6074  
[DRPperformance.net](http://DRPperformance.net)  
[DRPuniversity.tv](http://DRPuniversity.tv)



## Center to Center Tool

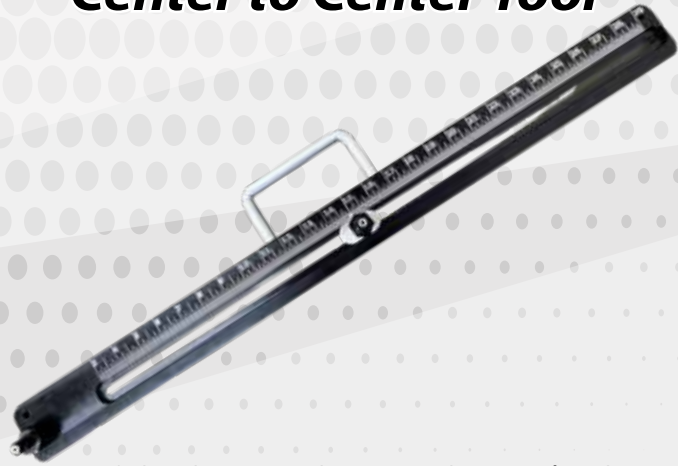

Measure & Set Center to Center on Suspension Struts, Panhard Bars, Shocks, Sway Bar Links & more  
Includes 3/8", 1/2", 5/8" & 3/4" Adapters  
Great for Calibrating Sensors-Includes 10-24" Adapters  
2" - 29" Range

007 95201 Center to Center Strut Tool \$348.50

## Shock Travel Indicators



- Measures Shock Compression & Extension
- Replaces O-Ring Travel indicators
- Mounts to Shock Bolt
- Quickly Measures Center to Center with Pointer

007 95200 Shock Travel Indicator \$115.00

## Wheel Plates

Adjustable height.

Base plate to mimic contact patch.

+/- 15deg Camber

Pull Down Ready.

Billet Aluminum with Black Powder Coat.



RS95010 Billet Wheel Plate with Swivel Base \$312.00  
RS95012 5x5 Adapter for Wheel Plate \$52.00

## Adjustable Set-Up Struts



- Quick Pin Adjustments Every 1/4"
- Laser Etched Centerline Measurements
- 1/2" Rod Ends for Fine Adjustment

007 95160 Quick Adjust Strut 14"-20.5" \$99.95  
007 95160-1 Quick Adjust Strut 20"-26.5" \$99.95  
007 95160-2 Quick Adjust Strut 24"-30.5" \$99.95



## Precision Rear End Fixture



**A Premium Tool to Measure & Straighten  
Rear End Axle Tubes.  
Measure Toe & Camber to .001".  
Measure Side Bells**



007 92005	Precision Rear End Fixture for Quick Change with Digital Caliper	\$2485.00
007 92006	Standard Rear End Fixture for Quick Change (Use with Tape Measure)	\$1985.00
007 92010	5x5 Adapter Plates (2 Required)	\$125.00

## Spindle Fixture

- Measure Spindles
- Check For Bent Spindles
- Repair Spindles
- Build Custom Spindles



007 80200 Spindle Fixture -K727 Lower Ball Joint \$1185.00  
 007 80202 Spindle Fixture -K6141 Lower Ball Joint \$1185.00  
 007 80270 Additional Steering Arm Fixture \$215.35

## Wide Five Rim Saver



**A Premium Tool to Prevent Bending Wide Five  
Wheels During Tire Mounting & Dismounting**

007 81100 Wide Five Rim Saver - Threaded Studs \$199.85  
 007 81102 Wide Five Rim Saver -High Volume - Smooth Studs \$277.35



**888-399-6074**  
**DRPperformance.net**  
**DRPuniversity.tv**

# RS400PRO

## Four Wheel/Dual Laser Alignment System



Measure Four Wheel Toe, Camber, Rear End Skew, Contact Patch Alignment & Wheel Base in 30 Minutes!  
Dynamically measure: Bump Steer, Rear Steer, Ackerman & More.



RS90400P-ALM	RS400PRO for Straight Rail Asphalt Late Models	\$3985.00
RS90400P-LMSC	RS400PRO for NASCAR Late Model Stock Cars	\$3985.00
RS90400P-NMOD	RS400PRO for NASCAR Tour Type Modifieds	\$4150.00
RS90400P-DLM	RS400PRO for Dirt Late Models	\$4150.00
RS90400P-DMOD	RS400PRO for Dirt Modifieds	\$3985.00
RS90400P-AMOD	RS400PRO for Asphalt Modifieds (8" Tire)	\$3985.00



## RS200PRO Two Wheel/Single Laser Alignment System



90200P-ALM RS200PRO for Straight Rail \$2285.00  
Specify Chassis Type

## Real Square Accessories

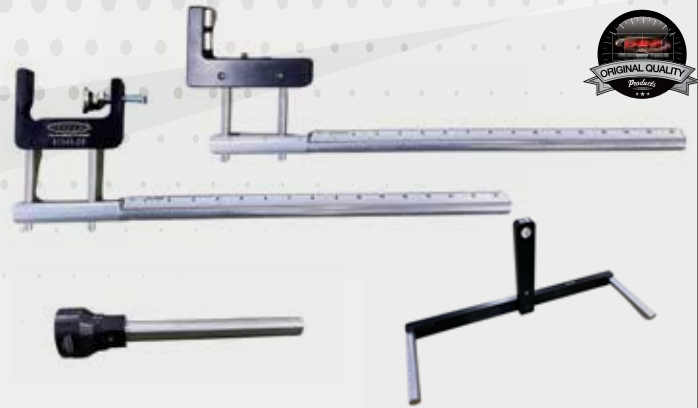

PD19200	Alignment & Pull Down Storage Cart	\$1250.00
96500A	Dual Axis Camber/Dynamic Caster Gauge	\$249.00
98300	Magnetic Wheel Base Tool	\$46.50
98301	Contact Patch Measurement Attachment	\$48.00
97142	Axle Alignment Fixture - W/F	\$189.00
97210	Wheel "T" Fixture with 8" Rulers	\$262.00
97232	Frame Square - Magnetic (LMSC)	\$195.00
97234	Frame Square - Clamp-on (Straight Rail)	\$147.00

## Slip Plates



- Increase Scaling and Alignment Accuracy
- Relaxes Tire. Eliminates Rolling Car Back & Forth
- Aluminum Plates with PTFE Sheets. No Mess!

007 90301A Slip Plates Set - 4 Plates & Sheets \$280.00  
007 90306 Replacement PTFE Sheet \$29.50

## Ground Plane Laser Ride Height Kit



- Kit Includes Adjustable Laser Holder (Billet Aluminum & Stainless Steel Shaft, Self-Leveling Laser, (4) Magnetic 8" Carbon Rulers

PD21801 Ground Plane Laser Kit \$550.00  
PD21800.8 Replacement 8" Carbon Ruler \$38.35



888-399-6074  
DRPperformance.net  
DRPuniversity.tv

# Advanced Chassis Set-Up. Short Track Price.

## DSS-2

**Our latest Level Set-Up System with . Build as You Grow.**

- Measures Chassis Wheel Weights & Balance, Shock Centerlines OR Frame Heights, Shock Travel Center of Gravity Position + 8 Channel System. 10" Wireless Tablet Display. Lightweight 10" Scale Stands. Pulls Chassis Down to Measure On-Track Balance & Wheel Positions.

**Dirt or Asphalt!**



STAGE 1 – Pull Down Kit	STAGE 2 – Pull Down System	STAGE 3 – System with Scales
Pull Down Cylinders	Stage 1 Plus:	Stage 2 Plus:
Chassis Mounts	10" Pull Down Stands & Roll Offs.	DRP High Load Pull Down Scales
Floor Mounts		10" Wireless Tablet Display
Precision Joystick Control		Optional Shock or Ride Height Sensors

**Modular System. Start complete or build as you grow.**

- **Stage 1 Kit:** Everything your need to pull down your race car except scales & stands. Cylinders, Chassis Mounts, Floor Mounts, Slip Plates, Precision Joystick Control.
- **Stage 2 Pull Down System:** Everything in Stage 1 Plus 10" Lightweight Pull Down Stands with Roll Offs. Just add your scales and you're ready to pull down.
- **Stage 3 System with Scales:** Stage 2 System with DRP High Load Pull Down Scales. These are purpose built scales for Dynamic Scaling.

**Optional: Shock Sensors or Frame Height Sensors**



Displays Wheel Weight/Load, Shock Center-line, Shock Travel OR Frame Heights at the same time! Eliminate the tape measure!



Measure & Graph Center of Gravity Position.



Wirelessly view control on any device. Phone, Tablet, Computer & TV

**Email or Text for a DSS-2 Brochure: [sales@drpperformance.com](mailto:sales@drpperformance.com) 1-833-269-7736**

PPD19020	DSS-2 Stage 1 Pull Down Kit - Asphalt	\$5995.00
PD19020D	DSS-2 Stage 1 Pull Down Kit - Dirt	\$6495.00
PD19030	DSS-2 Stage 2 Pull Down System Complete no Scales- Asphalt (No Scales)	\$8590.00
PD19030D	DSS-2 Stage 2 Pull Down System Complete no Scales - Dirt (No Scales)	\$8995.00
PD19040	DSS-2 Stage 3 Pull Down System Complete with Scales - Asphalt	\$14,475.00
PD19040D	DSS-2 Stage 3 Pull Down System Complete with Scales- Dirt	\$14,975.00

**Fix Problems. Find Speed. Unload Faster.**

# DSS-3

## NEW! 4th Generation Dynamic Scaling System ALL-IN-ONE Chassis Set-Up

**Save Time while Improving Your Set-Up Accuracy!**

- Measure & Adjust On-Track Balance.
- Find & Fix Problems.
- Test Ideas in the Shop.
- Increase Consistency & Speed.

• Measures Chassis Wheel Weights & Balance,  
Shock Centerlines, Frame Heights, Shock Travel  
Center of Gravity Position +

16 Channel System. 7" Industrial Touchscreen. 10" Wireless Tablet Display.  
Billet 12" Tall Scale Stands.

Pulls Chassis Down to Measure On-Track Balance & Wheel Positions.

Variable Speed Joystick Controls. USB Data Download. 7" Touch Screen Display.  
Industrial Quality Components. Complete User Manual & Data Analysis Training Included.



Displays Wheel Weight/Load, Shock Center-line,  
Shock Travel & Frame Heights at the same time!  
Eliminate the tape measure!



Measure & Graph Center of Gravity Position.



Graph Wheel Load Curves  
Overlay & Compare Tests



Wirelessly view control on any device.  
Phone, Tablet, Computer & TV



4 Spare Sensor Channels.  
Add Bump Stop, Droop Limiter, Sway Bar Load  
Cells & More.



Compare Wheel Loads after Making Adjustments



FINANCING  
AVAILABLE

**Email or Text for a DSS-3 Brochure: [sales@drpperformance.com](mailto:sales@drpperformance.com) 1-833-269-7736**

- PD19003-4G DSS-3 Standard Pull Down System \$18,555.
- PD19113A-4G DSS-3 4th GEN Graphing Pull Down System with Shock Position Sensors \$22,998.
- PD19003D-4G DSS-3 Standard Pull Down System \$19,730.
- PD19113D-4G DSS-3 4th GEN Graphing Pull Down System with Shock Position Sensors \$24,175.

**Dirt or  
Asphalt!**



**888-399-6074**  
**DRPperformance.net**  
**DRPuniversity.tv**

# Champion Proven Professional Chassis Set-Up.

## DSS-4

**DSS-4 Automated Chassis Set-Up System**  
**Scale • Shock CL • Frame Heights • Pull Down • Analyze**  
**Automated Chassis Movement + Acceleration**

The Premier Short Track Set-Up System.  
 Automated Tests for Maximum Repeatability.  
 High Accuracy. Easy to Use.

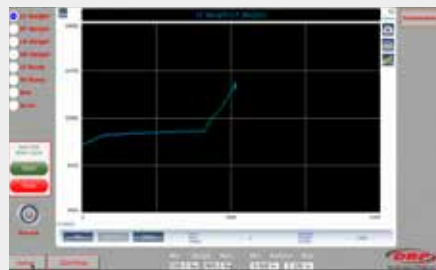

Email or Text for a DSS-4 Brochure: [sales@drppperformance.com](mailto:sales@drppperformance.com) 1-833-269-7736

New Software!

Capture & Compare Set-Ups. Automatically Creates Notebook pages. Displays Shock Centerline & Travel. Fully Automated. Enter your travels or loads and press start!

**Dirt or Asphalt!**



FINANCING AVAILABLE

PD19114A  
 PD19114AM

DSS-4 Automated Chassis Set-Up System - Specify Chassis Type  
 DSS-4 Master Package (Pull Down, RS400PRO, Ground Plane Laser)

\$41,950.00  
 \$46,650.00

# Better Data. Better Decisions.

## 8+ Pro Wifi Data Acquisition System Professional Level Data Acquisition for Any Level Team.



*Dirt or Asphalt!*



*Includes Online Video Training*

- 8 Channels Standard - Expandable to 32+
- Wireless Data Downloading via Wifi
  - Turn Key System - Ready to Use
  - Ships with 4 Shock Sensors
- GPS Track Mapping, RPM, Lap Times, Segment Times, G-Loads & Software Included.

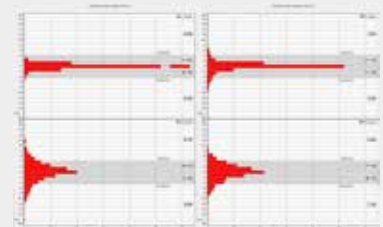
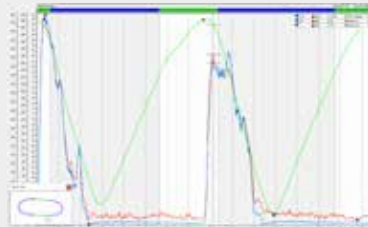
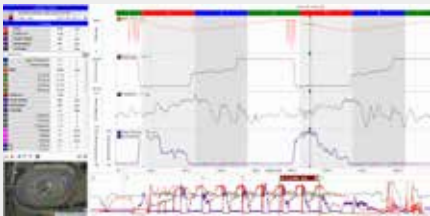

DA21400AL	8+ PRO Data Acquisition System with Linear Shock Sensors	\$4695.00
DA21400A	8+ PRO Data Acquisition System with Premium String Shock Sensors	\$5695.00

## 4+ Pro Wifi Data Acquisition System *Build as you go.*



- 4 Channels Standard - Expandable to 32+
- Wireless Data Downloading via Wifi
- GPS Track Mapping, RPM, Lap Times, Segment Times, G-Loads & Software Included.
- No Sensors Included. Use as is or Add Sensors of your choice.

*Includes Online Video Training*

DA21310 4+ PRO Data Acquisition System - No Sensors Included \$2650.00

## Solo Mini 4 Channel Data Acquisition System



- Very Compact & Simple
- 4 Channels • Works as In Car GPS Lap Timer & Data Logger • GPS, RPM, Track Mapping, Segment Times
- Hardware Only Kit - No Sensors
- Driver Kit - Steering, Throttle, (2) Brake Pres.
- Susp. Kit - (4) Linear Shock Sensors

DA22020	Solo Mini Hardware Only Kit	\$1089.
DA22030	Solo Mini Driver Kit	\$2985.
DA22040	Solo Mini Suspension Kit	\$2850.

## MXG Dash Data Logger



- 7" TFT Dash • Fully Configurable Screen
- Full Data Logger with GPS
- 8 Open Channels for Sensors
- Expandable for Additional Sensors
- View Live Data on Screen
- Download to Race Studio Software for Analysis

DAMXG MXG Dash Data Logger \$2899.00

### Linear Shock Sensors



DA21605-75	3" Stroke Shock Sensor	\$289.90
DA21605-150	5.9" Stroke Shock Sensor	\$289.90
DA21605-200	7.8" Stroke Shock Sensor	\$289.90
DA21605-250	9.8" Stroke Shock Sensor	\$289.90

### String Style Shock Sensors



DA21608	26" String Style Shock Sensor	\$469.00
DA21607	String Shock Sensor w/Mounts	\$495.00

### Shock Sensor Mounts



Slip-On Shock Sensor Mount - Short	\$17.50
Slip-On Shock Sensor Mount - Std	\$17.50
Slip-On Shock Sensor Mount - Long	\$17.50
Shock Sensor Extension Mount	\$24.00
Round Tube Shock Sensor Mount	\$24.00
Deluxe Shock Sensor Mount Kit (62 pcs)	\$329.00

### Steering Sensor



DA21655	Rack Mt. Steering String Sensor	\$430.
DA21608	Universal Steering String Sensor	\$469.

### Throttle Sensor



DA21650	String Style Throttle Sensor	\$419.
DA21650-1	Bay Bar Mount for Throttle Sensor	\$15.00

### Brake Pressure Sensor

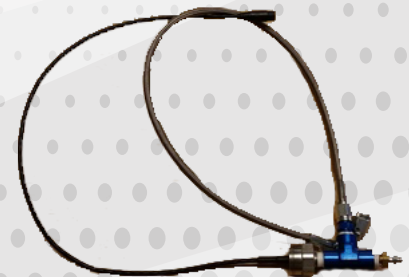

- Kit Includes (1) Sensor, Whip Line, Bleeder, Tee

DA21670	Brake Pressure Sensor Kit	\$220.00
DA21675	Brake Pressure Sensor Only	\$180.00



### Tire Temp Sensors



- Infra Red Sensor
- 1 Sensor Gives 4 Individual Temps Across Tire
- Kit Includes (2) Sensors, Harness & for Data Logger
- CAN (Digital) Sensors - Does not use Analog channels

DA21685 Tire Temp Sensor Kit - Front \$1633.  
 DA21685 Tire Temp Sensor Kit - Rear \$1633.

### GPS Receiver



- Included with all Systems

DAGPS09S GPS Receiver 1.5m \$349.  
 DAGPS09L GPS Receiver 4m \$349.

### Smarty Cam Sport



- Syncs with Data System or Stand Alone
- Displays Sensor Data On Screen with Video
- Can add GPS Antennae for stand alone use.
- Extremely Compact. 30fps Video.

DA22502 Smarty Cam Sport \$899.

### Solo Lap Timer



DA22000 Solo 2 GPS Lap timer - Std \$459.  
 DA22010 Solo 2 GPS Lap Timer w/RPM \$799.

### Data Hub Digital Channel Expander



- Add Channels to Your Data System
- Works with 4+ & 8+ Wifi (EVO-5), EVO-4S, EVO-4 & MXG Data Loggers

DA21560 4 Channel Digital Expander \$78.

### Sensor Cables



Custom Sensor Cables  
 Specify Snap to Snap (EVO-5 Series)  
 or Snap to Screw (EVO-4 Series)

DA 21602-2' Premium Sensor Cable \$69.00  
 DA 21602-4' 4' premium Sensor Cable \$69.00  
 DA 21602-6' 6' premium Sensor Cable \$69.00  
 DA 21602-8' 8' premium Sensor Cable \$69.00  
 DA 21602-10' 10' premium Sensor Cable \$69.00  
 DA 21602-12' 12' premium Sensor Cable \$69.00  
 Custom Length Premium Sensor Cable \$79.00

### 4 Channel Analog Channel Expander



- Add Channels to Your Data System
- Works with 4+ & 8+ Wifi (EVO-5), EVO-4S, EVO-4, Solo & MXG Data Loggers

DA21550 4 Channel Analog Expander \$419.00

### Wheel Speed Sensors



- Kit Includes: 2 Wheel Speed Sensors with Cables

DA21681 Wheel Speed Sensor Kit \$210.

### Engine Temp & Pressure Sensors



DA21674 Oil Temperature Sensor \$75.00  
 DA21671 Water Temperature Sensor \$75.00  
 DA21672 Oil Pressure Sensor \$159.00

**Data Sensors Work on DSS Systems Too!**

### Droop Limiter Load Cells



- All Data Systems Require Amplifier
- Includes Load Cell, Clevis & Jam Nut

DA21719 Droop Limiter Load Cell- 1/2" With Amp \$1266.  
 DA21719NA Droop Limiter Load Cell- 1/2" No Amp \$1067.  
 DA21701 Load Cell Amplifier \$199.

### In-line Load Cells



- All Data Systems Require Amplifier
- 3000LB Max Load
- Extremely Compact: 1" Body Length

DA21711 3/8"-24 Male & Female \$1067.00  
 DA21710 1/2"-20 Male & Female \$1067.00  
 DA21716 5/8"-18 Male & Female \$1067.00  
 DA21701 Load Cell Amplifier \$199.

### Bump Stop Load Cells



- All Data Systems Require Amplifier

DA21751 Bump Stop Load Cell with Amp \$899.  
 DA21751NA Bump Stop Load Cell Only \$699.  
 DA21701 Load Cell Amplifier \$199.

### Sway Bar Load Cells



- All Data Systems Require Amplifier

DA21715NA SB Load Cell-1/2" Solid (3" CL) No Amp \$1067.  
 DA21718NA SB Load Cell-3/8" Solid (3" CL) No Amp \$1067.  
 DA21716NA Sway Bar Load Cell-Slapper Style-No Amp \$1067  
 DA21701 Load Cell Amplifier \$199.

### Trailing Arm Load Cells



- 5000LB Max Load
- All Data Systems Require Amplifier

DA21713 Trailing Arm Load Cell-5/8"-w/Amp \$2385  
 DA21713NA Trailing Arm Load Cell Only \$2186  
 DA21701 Load Cell Amplifier \$199.

### Coil Spring Load Cell



- Replaces Jack Screw & Spring Cup For 5" Springs
- Amplifier Required for all Data Systems

DA21722 Coil Spring Load Cell w/Amp \$1249.  
 DA21722NA Coil Spring Load Cell Only \$1050.  
 DA21751NA Replacement Load Cell Only \$699.  
 DA21701 Load Cell Amplifier \$349.

### Coil Over Load Cell



- Replaces Bottom Spring Cup - For 2.5" Spring
- Amplifier Required for all Data Systems

DA21720 Coil Over Spring Load Cell w/Amp \$945.  
 DA21720NA Coil Over Spring Load Cell Only \$749.  
 DA21751NA Replacement Load Cell Only \$699.  
 DA21701 Load Cell Amplifier \$199.

### Laser Ride Height Sensor



- Sold Individually
- CAN (Digital) Sensors - Does not use Analog channels

DA22501 Laser Ride Height Sensor \$1800.

### Lateral Grip Sensor



DA21660 Lateral Grip Sensor \$219.

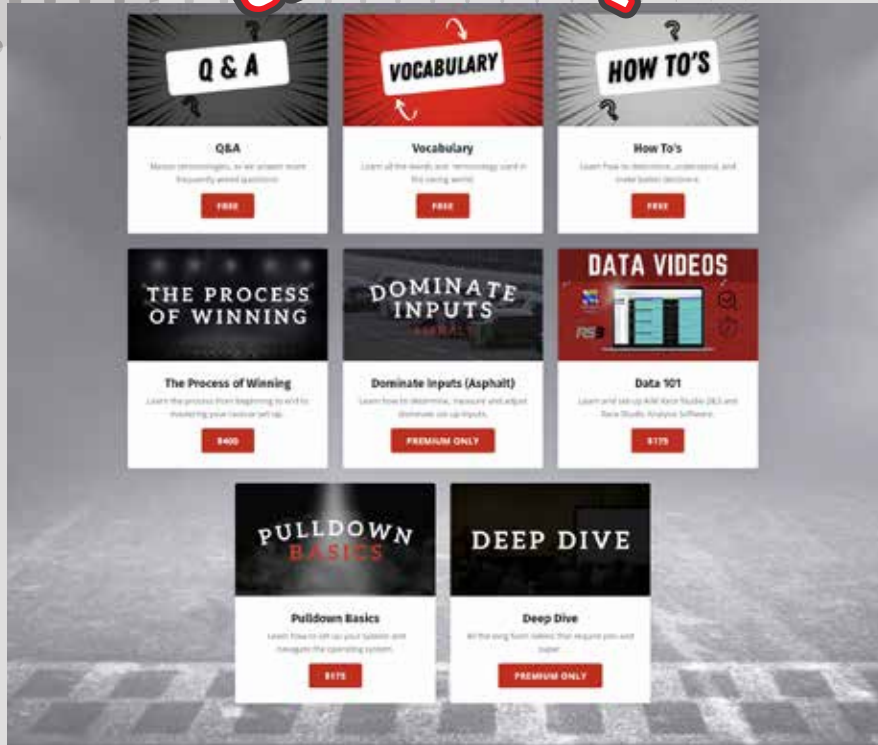

**KNOWLEDGE = SPEED**

## **Online Video Training**

**Free & Paid Videos & Courses**

**Hours of Seminars and In-Depth Suspension Training**

**Set-Up Process, Suspension Understanding, Adjustment Explanation, Team Building, Data Analysis. For Crew Chiefs, Drivers, Team Owners & Anyone who wants to learn!**

**Lifetime Premium Access to All Content \$1750.00!**

**[www.DRPUniversity.tv](http://www.DRPUniversity.tv)**

## **Live Seminars & Workshops**

**In person group learning. Classroom & hands-on.**

## **In Person 1:1 Set-Up Coaching & Race Car Analysis**

**Custom training, set-up, pull-down & data acquisition services.**



**888-399-6074**  
**[DRPperformance.net](http://DRPperformance.net)**  
**[DRPuniversity.tv](http://DRPuniversity.tv)**

**Want to find some more speed?  
Check out our Low Drag Components Catalog!**

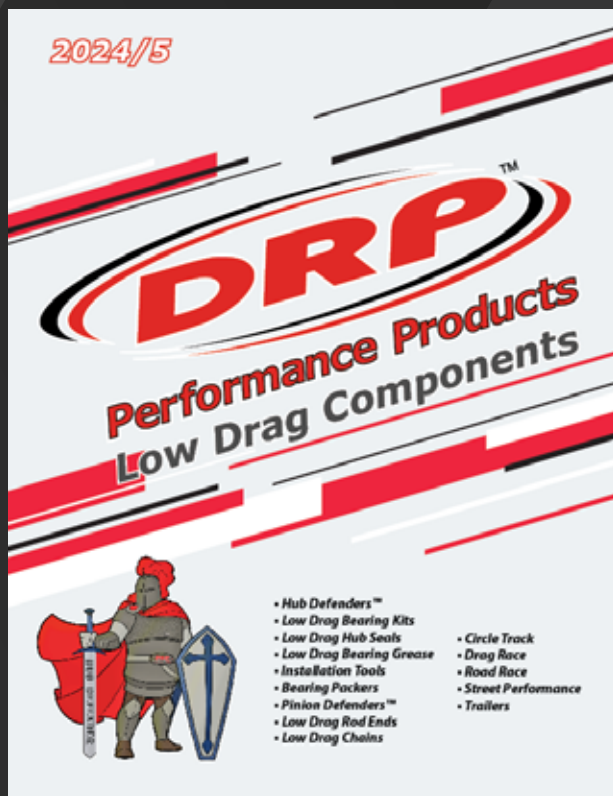

### **Warranty Disclaimer**

Motor sports are very dangerous. Products are sold "as is" and user assumes all risk. DRP Performance Products, Inc. makes no warranty express or implied.

Prices are for reference only and subject to change without notice.

**888-399-6074**  
**DRPperformance.net**  
**DRPuniversity.tv**

*"...let us run with endurance the race that is set before us..." Hebrews 12:1*